



# XLERATOR® HAND DRYER

MODELS: **XL - BW** **W** **GR** **C** **SB** **SI** **SP** OPTIONS: **-1.1N** (Noise Reduction Nozzle) **-H** (HEPA Filter) **-VOLTAGE** (See Chart)



**XL-BW**  
White Thermoset Resin (BMC)



**XL-W**  
White Epoxy Painted



**XL-GR**  
Graphite Textured Painted



**XL-SP\*\***  
Custom Special Paint



**XL-SI\*\*\***  
Custom Special Image



**XL-C**  
Chrome Plated



**XL-SB**  
Brushed Stainless Steel



UL Environment published the first global Product Category Rules (PCR) for Hand Dryers. The PCR created evaluation methods through industry consensus that compare products' environmental impact and performance. Third party testing results then allow for the creation of certified Environmental Product Declarations (EPDs).



An EPD is a comprehensive, internationally-harmonized report documenting a product's environmental impact over its lifecycle. They enable specifiers and buyers to make a true apples-to-apples comparison of products and make more informed product selections. Excel Dryer received the industry's first certified EPDs.

\*Dry time and energy use testing performed by SGS International on standard XLERATOR Hand Dryer with 0.8" nozzle to 0.25g or less of residual moisture, pursuant to the UL Environment Global Product Category Rules (PCR) for Hand Dryers.  
\*\*Special Paint powder-coated covers are available in many colors and textures. \*\*\*Exclusive digital image technology allows for the addition of company, school or team logos with any color, design or a 'green message'.

## FOR ARCHITECT/ENGINEER APPROVAL

Job Name: \_\_\_\_\_ Date: \_\_\_\_\_  
 Model Specified: \_\_\_\_\_ Quantity: \_\_\_\_\_  
 Variations Specified: \_\_\_\_\_  
 Customer/Wholesaler: \_\_\_\_\_  
 Contractor/Architect: \_\_\_\_\_

## PERFORMANCE



**DRY TIME: 8 SECONDS\***

**ENERGY PER USE: 3.7 Wh\***

**ADJUSTABLE SOUND LEVEL:** 65 - 75 dB

**ADJUSTABLE VELOCITY:** 13,000 - 20,000 LFM

**ADJUSTABLE HEAT RANGE:** 72°F - 135°F

**FLOW RATE:** 42 - 63 CFM

**WATTAGE:** 1490 Watts (Heat On), 425 Watts (Heat Off)

## CONSTRUCTION

A. All covers will be fastened to a base plate by two chrome plated tamper-proof bolts. Cover shall be one of the following:

**Die-cast zinc alloy** – One-piece, heavy-duty, rib-reinforced, lightweight, unbreakable, rustproof and all exposed surfaces shall be bright chrome plated or finished with chip-proof, electrostatically applied epoxy paint.

**Bulk Molding Compound (BMC)** – White reinforced thermoset resin.

**Stainless Steel** – with a brushed finish.

**Special Image** – Digital image applied to die-cast or stainless steel covers using patented Kolorfusion Sublimation Decoration process.

B. Base plate shall be equipped with (3) 7/8" (22 mm) diameter holes, the bottom one is suitable for use with surface conduit.

C. All internal parts shall be coated according to Underwriters' Laboratories, Inc. requirements.

D. Entire mechanism shall be internally grounded.

E. Options

**HEPA Filtration System:** Filters 99.97% of bacteria at 0.3 microns from the air stream.

**1.1" Noise Reduction Nozzle:** Reduces the sound level by 9 decibels by significantly decreasing air deflection noise while only increasing dry time by approximately 3 seconds.

F. Accessories (optional)

**Antimicrobial Wall Guards:** 89W (Microban® White), 89B (Microban Black), 89S (Brushed Stainless Steel)

**XChanger Paper Towel Retrofit Kit:** 40550, 40551 (ADA Height)

**ADA Recess Kit:** 40502

## MECHANISM

A. Motor shall be a thermally protected, series commutated, through-flow discharge vacuum motor/blower (5/8 hp / 24,000 rpm) which provides air velocity of up to 20,000 LFM (linear feet per minute). Includes a washable metal mesh filter for more reliable performance.

B. Heating element (970 W) is constructed of Nichrome wire and mounted inside the blower housing, thereby being vandal resistant. It shall be protected by an automatic resetting thermostat, which shall open whenever air flow is cut off and shall close when flow of air is resumed. It shall produce an air temperature of up to 146°F (63°C) at a 72°F (22°C) ambient room temperature at the hands (4 inches [102 mm] below air outlet).

C. Control assembly is activated by an infrared optical sensor located next to the air outlet. The dryer shall operate as long as hands are under the air outlet. Control includes a speed and sound control mechanism, adjustable heat control with High, Medium, Low and Off settings and a filter sensor which is activated should the filter become clogged. There is a 35-second lockout feature if hands are not removed. Sensor equipped with externally visible red LED light that flashes error codes to assist in troubleshooting.

## LIMITED WARRANTY

The dryer shall be guaranteed to be free from defects for a period of seven (7) years. Warranty shall include labor performed at factory as well as the repair or exchange of defective parts, at manufacturer's option.

## QUANTITY RECOMMENDATIONS

One dryer for every two washbasins is sufficient for most applications. If restroom traffic is unusually heavy, we suggest one dryer per washbasin in small installations and two dryers for every three washbasins in larger installations. When a 54" washfountain is used, we suggest four to five dryers.

EXCLUSIVELY DISTRIBUTED IN THE PHILIPPINES BY INFINITE BRANDS TRADING, INC.

Unit 301 Narra Building,  
2276 Pasong Tamo Extension  
Makati City, Philippines 1231

T. +632 8286 5464 / +632 8292 9083  
E. xlerator@infinitebrandstrading.com  
W. www.infinitebrands.ph



# XLERATOR® HAND DRYER



MODELS: **XL - BW W GR C SB SI SP** OPTIONS: **-1.1N** (Noise Reduction Nozzle) **-H** (HEPA Filter) **-VOLTAGE** (See Chart)

## SIDE VIEW

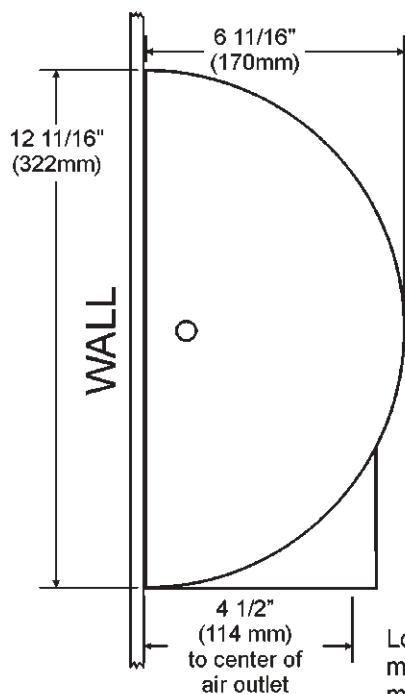

## FRONT VIEW FACING WALL

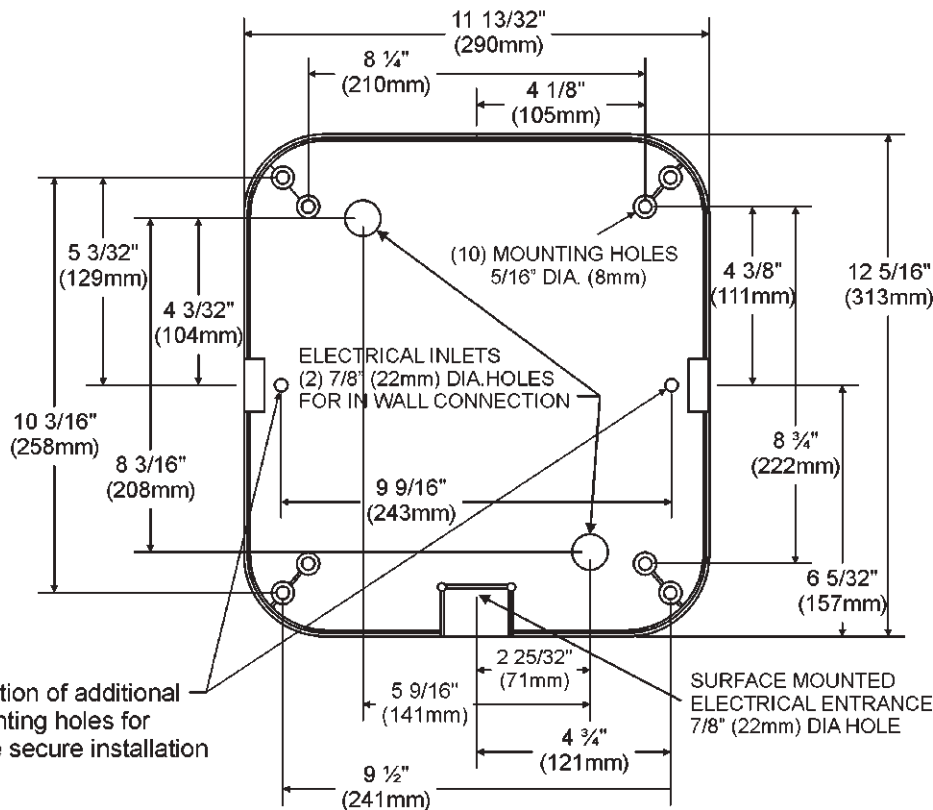

Location of additional mounting holes for more secure installation

## DIMENSIONS

Width 11 3/4" (298 mm) Height 12 11/16" (322 mm) Depth 6 11/16" (170 mm)

## WEIGHT

XL-BW: 15 lbs. (6.8 kgs.) XL-SB: 16 lbs. (7.26 kgs.) XL-W, GR, C, SI, SP: 17 lbs. (7.71 kgs.)

## ELECTRICAL

VOLTS	AMPS	WATTS	NO HEAT AMPS	NO HEAT WATTS	HERTZ	
110-120V	11.3-12.2A	1240-1450W	4.3-4.5A	460-530W	50/60 Hz	
208-277V	5.6-6.2A	1160-1490W	2.0-2.2A	425-500W	50/60 Hz	
230V	6.1A	1410W	2.2A	500W	50 Hz	

## SUGGESTED MOUNTING HEIGHTS

from floor to bottom of dryer:

Men	45" (114 cm)
Women	43" (109 cm)
Teenagers	41" (104 cm)
Small Children	35" (89 cm)
Accessible	37" (94 cm)

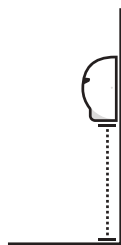

## CERTIFICATIONS



## ACTIVATION

Automatic Sensor Operated

## MOUNTING

Surface Mounted

## OPTIONAL ADA-COMPLIANT RECESS KIT



Part # 40502

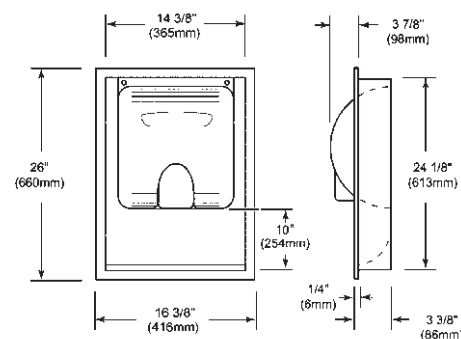

## DIMENSIONS

Width 16 3/8" (416 mm) Height 26" (660 mm) Depth 3 3/8" (86 mm)

## WEIGHT

11 lbs. (4.99 kgs.)

Bottom of recessed wall box should be 10" (254 mm) below suggested mounting height for dryer.

EXCLUSIVELY DISTRIBUTED IN THE PHILIPPINES BY INFINITE BRANDS TRADING, INC.

Unit 301 Narra Building,  
2276 Pasong Tamo Extension  
Makati City, Philippines 1231

T. +632 8286 5464 / +632 8292 9083  
E. xlerator@infinitebrandstrading.com  
W. www.infinitebrands.ph

